

**FAST
FREIGHT
MARCONI**



IL CARGO HANDLING AGENT DI RIFERIMENTO SULLO SCALO DI BOLOGNA

INFRASTRUTTURE

Le nuove celle per merce a temperatura controllata

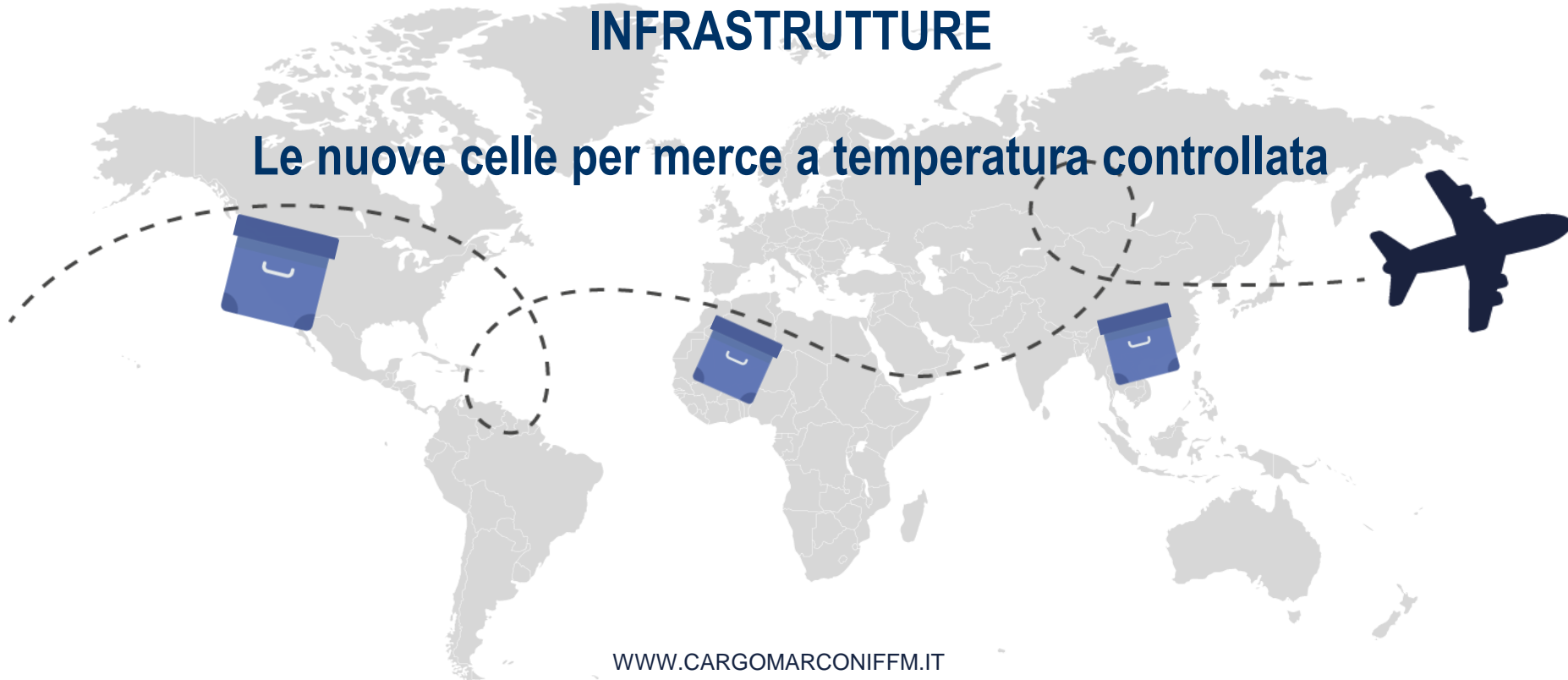

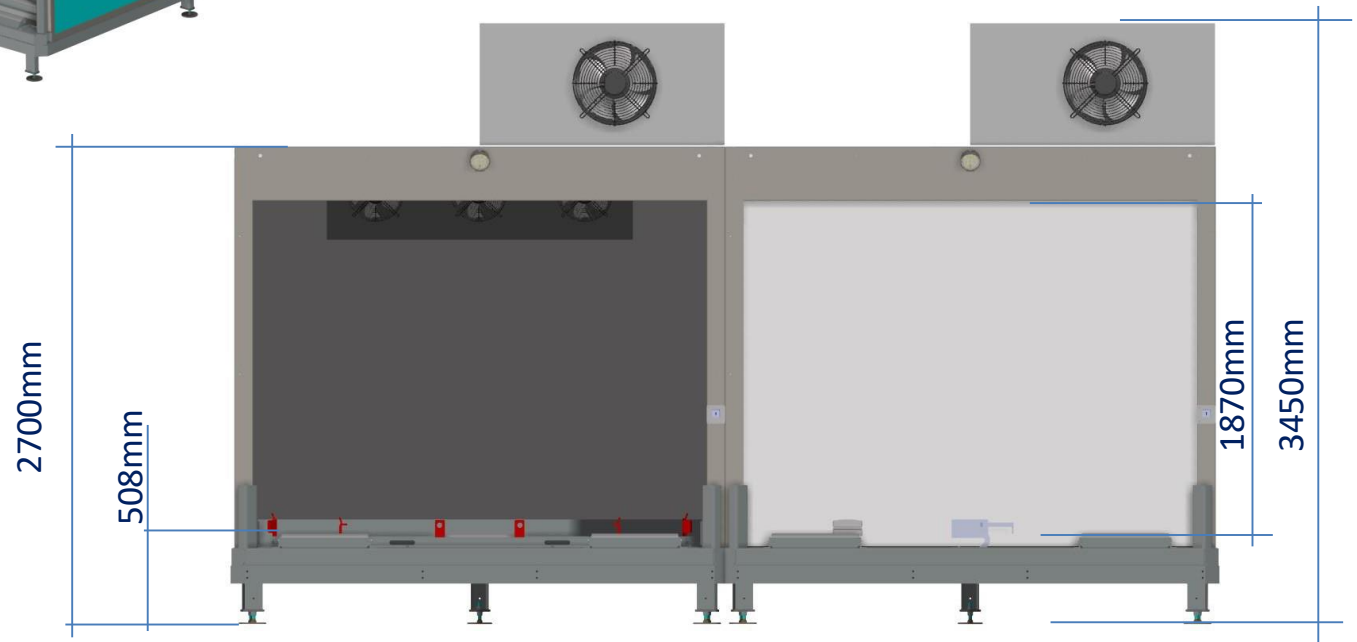
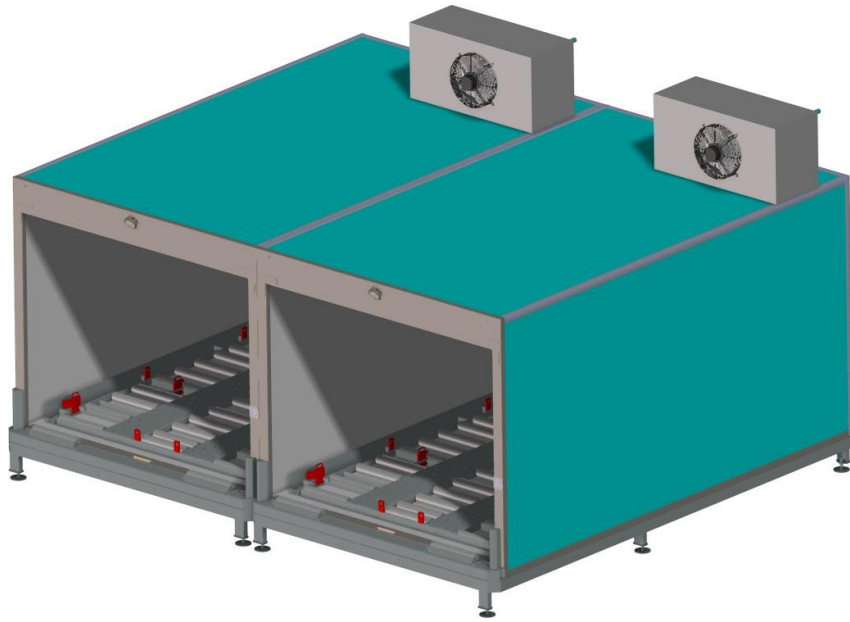

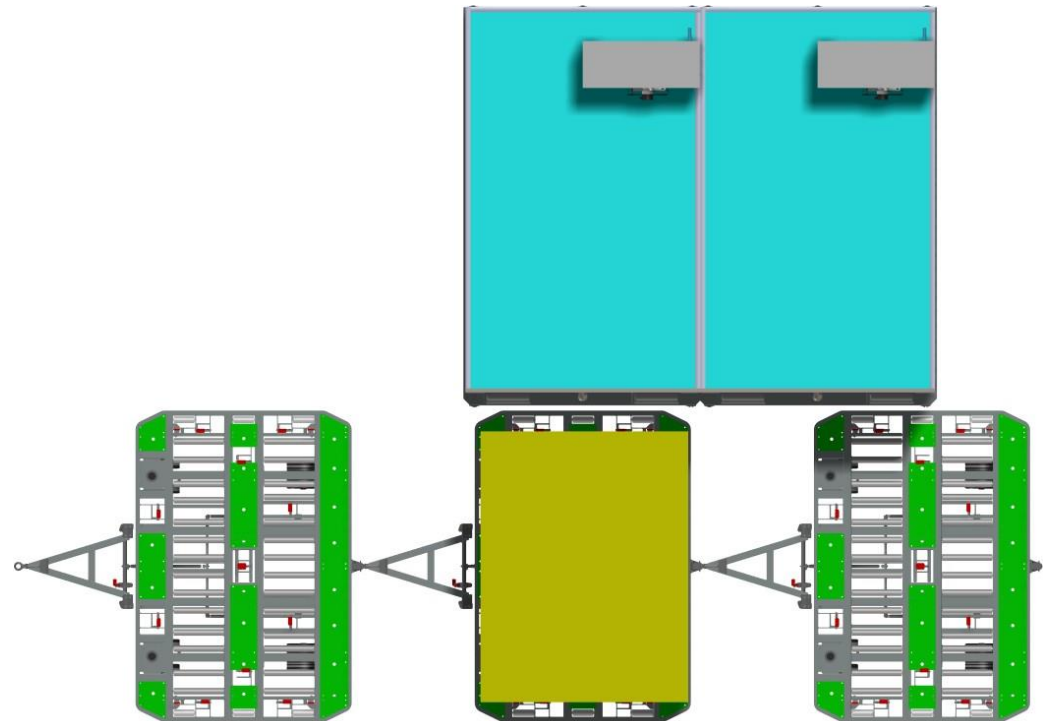
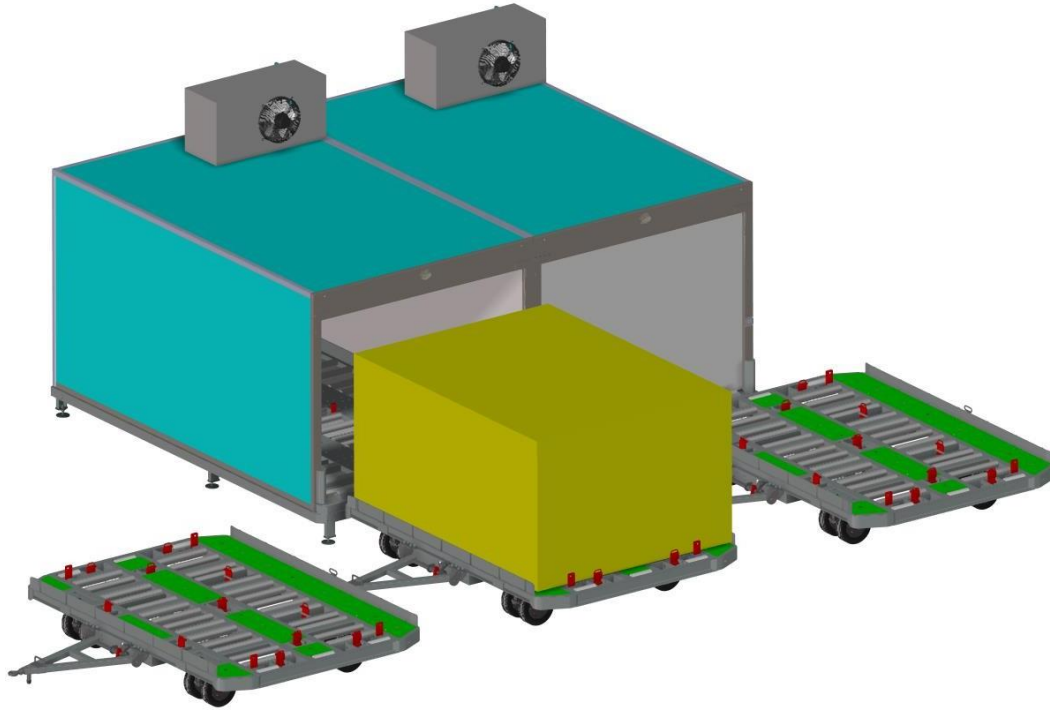



- Possibilità di allocare fino a 2 PMC/PAG;
- Possibilità di allocare altre tipologie di ULD di spazio equivalente;
 - Possibilità di stoccare colli singoli;
 - Temperatura controllata e variabile, da + 4° a – 20° ;
- Saracinesche con chiusura manuale per la massima sicurezza;
- Stoccaggio all'interno dell'area sicura di Fast Freight Marconi

VOLETE SAPERNE DI PIU': BASTA CHIEDERE!

bimbi@marconiffm.it

rosato@marconiffm.it

FAST
FREIGHT
MARCONI



GRAZIE PER L'ATTENZIONE!

